

Quartz Crystal

SMD-version

model	KX – 9AT
frequency	8,0 MHz
mode	fundamental
operating temperature	-40° ~ + 85°C
frequency tolerance at +25°C	± 30 ppm
temperature tolerance -40° ~ + 85°C	± 100 ppm
load capacitance C_L	16 pF
series resonance R1 max.	100 Ohm
aging at 25°C (first year) max.	± 2 ppm
shunt capacitance C_O max.	5,0 pF
drive level in mW max.	0,05
contents of reel	1000 pcs.
part no.	12.89048

Dimensions (mm):

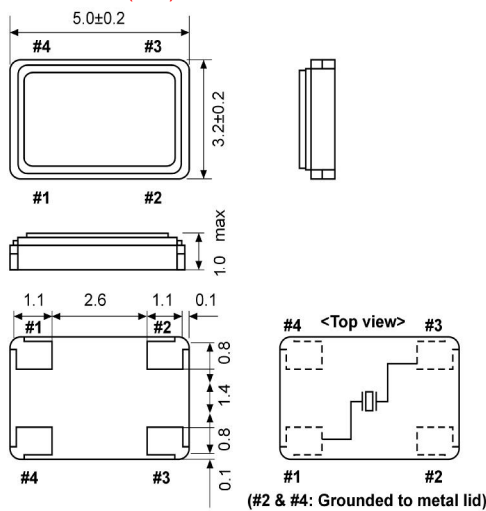

Reflow soldering condition:

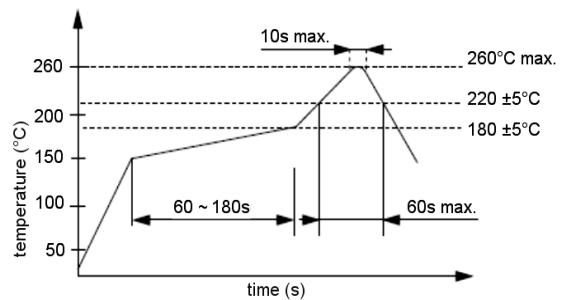

Tape specification:

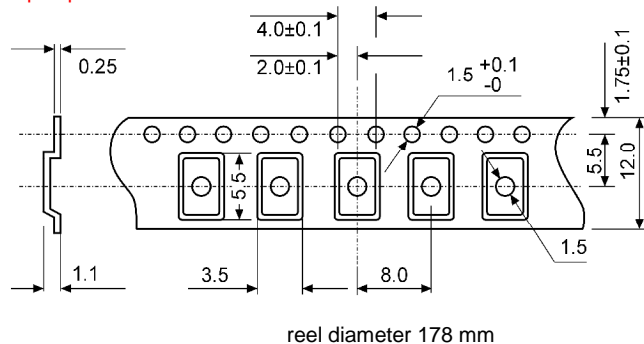

Suggested soldering pad:

